

U-TROUGH DRIVES

U-TROUGH POWERHEAD DRIVES are built for a long and solid service life. The housing is made with fully welded 12 gauge steel. Powerhead includes belts, pulleys, belt guard, downspout cover and driveshaft connecting fasteners.



(SHOWN WITH OPTIONAL INCLINE STAND)

20° INCLINE DRIVES

DESCRIPTION	ELECTRIC		HYDRAULIC	
	PART #	WT(lbs)	PART #	WT(lbs)
6"-8" 25° Inclined Powerhead	602-68-4002	166	602-68-4000	151
8"-10" 25° Inclined Powerhead	802-81-4002	216	802-81-4000	201
10"-12" 12° Inclined Powerhead	102-11-4002	265	102-11-4000	248
Hyd. Motor w/flow control			HYD-00-1100	8
6-8" Incline Support Stand	602-IS-4002			
8-10" Incline Support Stand	802-IS-4002			
10-12" Incline Support Stand	102-IS-4002			

HORIZONTAL DRIVES

DESCRIPTION	ELECTRIC		HYDRAULIC	
	PART #	WT(lbs)	PART #	WT(lbs)
8" U-Trough Horizontal Powerhead	802-00-1102U	94	802-01-1100U	85
10" U-Trough Horizontal Powerhead	102-00-1102U	115	102-01-1100U	109
Hyd. Motor w/flow control			HYD-00-1100	8

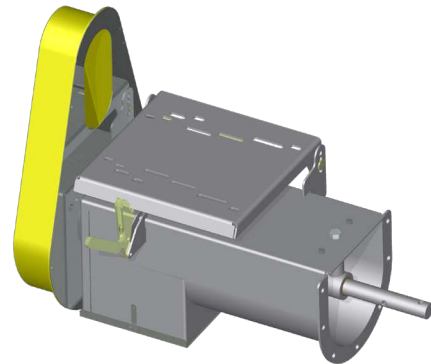

POWER SWEEP HORSEPOWER REQUIREMENTS

BIN DIA.	8"			10"		
	HORIZ.	INCL.	VERT.	HORIZ.	INCL.	VERT.
18'	5.0	7.5	15.0	7.5	10.0	15.0
21'	5.0	7.5	10.0	7.5	10.0	15.0
24'	5.0	7.5	10.0	7.5	10.0	20.0
27'	7.5	7.5	10.0	7.5	10.0	20.0
30'	7.5	10.0	15.0	7.5	15.0	20.0
33'	7.5	10.0	15.0	10.0	15.0	20.0
36'	7.5	10.0	15.0	10.0	15.0	20.0
42'	10.0	10.0	15.0	10.0	15.0	20.0
48'	10.0	15.0	20.0	15.0	15.0	25.0
54'				15.0	20.0	25.0
60'				20.0	20.0	30.0

Horsepower requirements were derived from operations using moderately dry grain. The specified values may not necessarily be sufficient for extreme work loads. The Limited Product Warranty does not cover equipment damaged by overpowered motors. Please heed all warnings. ROTATING AUGERS CAN CAUSE PERSONAL INJURY OR DEATH!

Haven Industries

67374 310TH St.
 Dexter, MN 55926
 Tel: 507.584.6300
 Fax: 507.584.0215
www.havenindustries.us

Distributed By:



Haven Industries

U-TROUGH POWER SWEEPS

GrainSaver

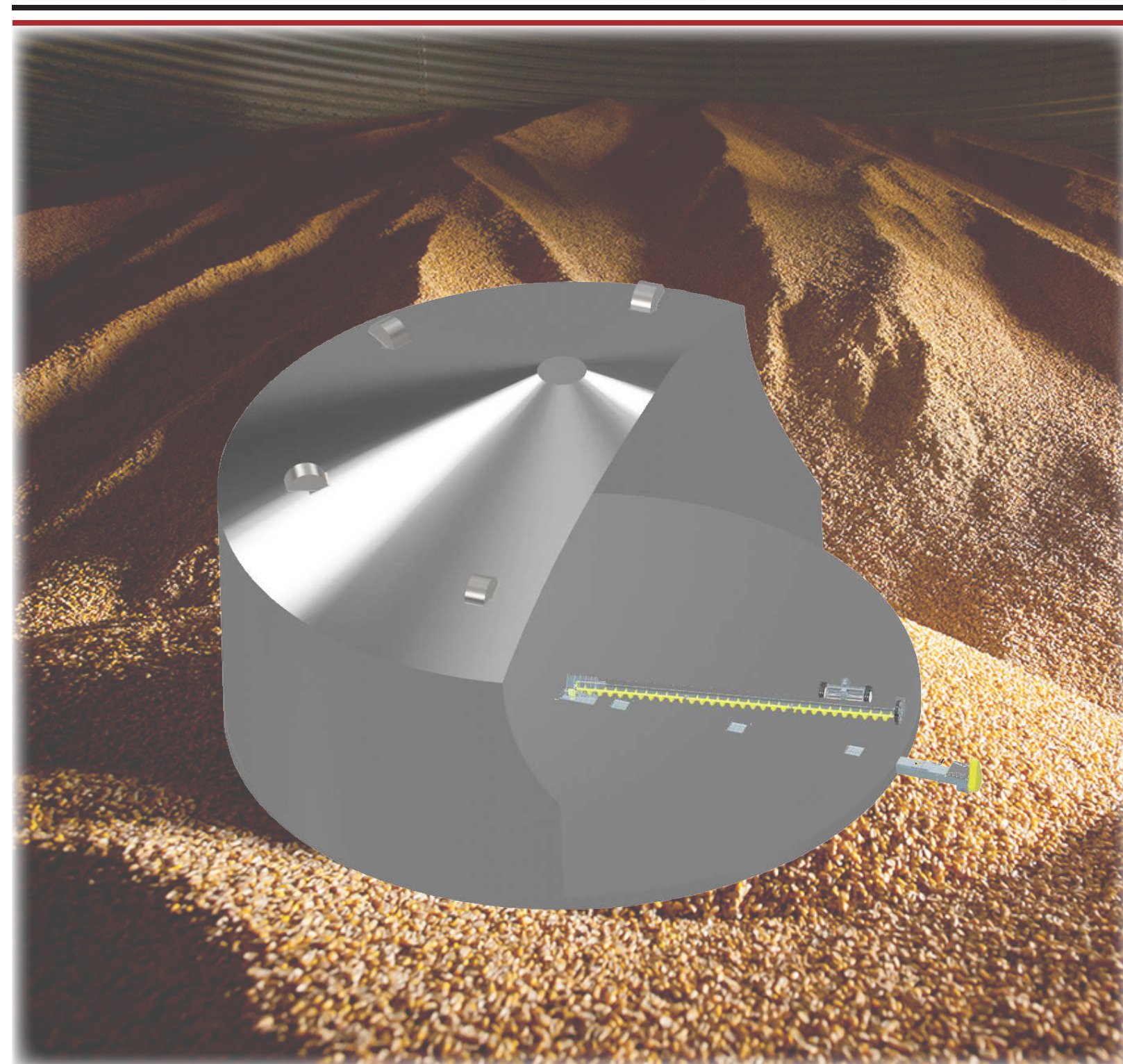

U-TROUGH POWER SWEEP

GRAIN SAVER® POWERSWEEPS are engineered to perform! Our simplistic, heavy-duty, fully-welded design will **maximize** productivity and lifespan, and **minimize** maintenance. Built around a 10" U-trough, with 9" or 7" flight options to match your application needs.

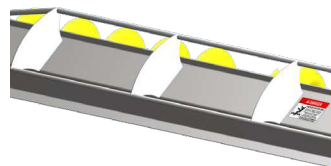

All models 42' and up have a 1/2" rod truss with welded braces every 2 feet.

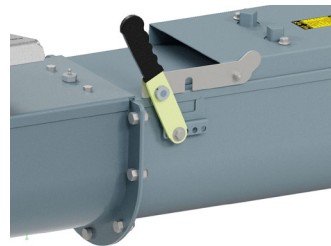

Adjustable gearbox engage lever with locking mechanism for smooth operation.

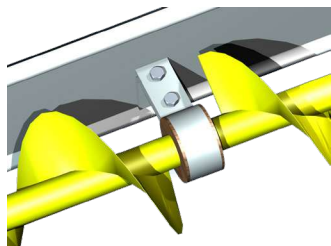

The sweep flighting is secured every 8-10' with a long life wooden hanger bearing.

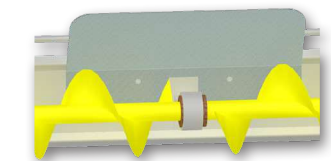

Spill shields prevent grain from spilling over backboards, leaving less manual labor for the operator.

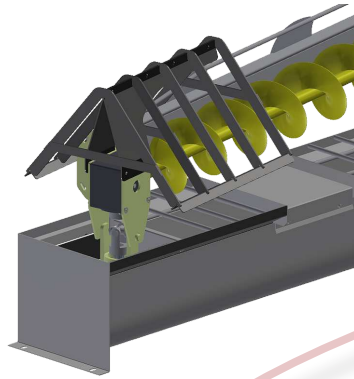

Easy to install, optional CLUMP BUSTER will help divert and break up clumps of grain that can clog up sumps.

Power sweep is shown with optional sweep tractor, reduction sweep drive wheel and extended sweep spill shield.

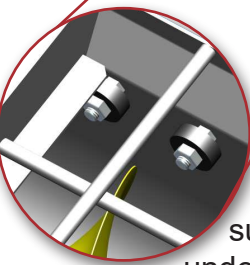

Steel rollers under the sump gate ensure easy sliding when under pressure.

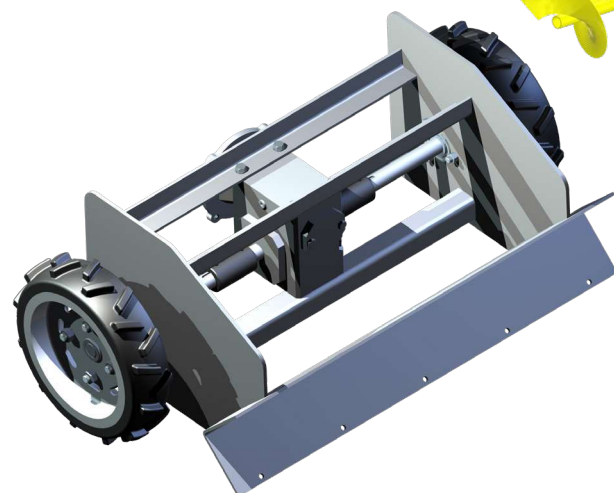

Sweep Tractor - We recommend all sweep models 66' and up to be fitted with a tractor. The tractor unit is powered by a 100:1 ratio gear reducer and an explosion-proof electric motor (motor not included). Foam-filled rubber tires maintain firm floor contact as the unit assists the backboard rotation.

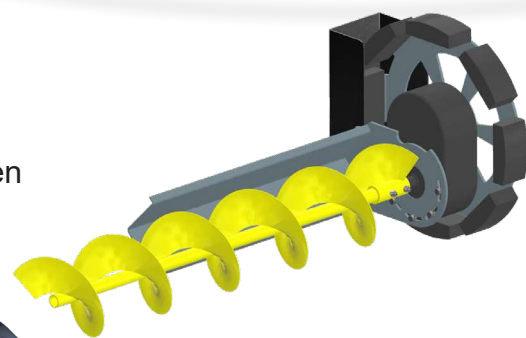

Our NEW 16.4:1 reduction wheel drive is designed to make bin sweeping a breeze. Superior long-life design with a fully enclosed gearbox with 8 individual rubber pads and a grain spill shield leaves less grain behind the wheel.

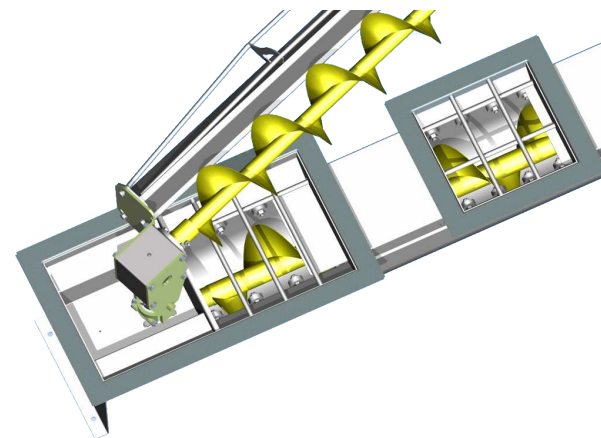

Center Hopper - Models 42' and up have a secondary center hopper as a standard feature. This addition acts as a backup & more grain flow and saves hours of unnecessary work if the center hopper becomes blocked by clumps. All hoppers are guarded by 1/2" safety rods welded to the hopper.

Standard Features...

The U-trough is made of 12 Ga. steel and capped by removeable 14 gauge covers.

Sweep Auger...

The sweep auger is coupled to the lower gearbox by a cast pivot, which can be quickly detached by removing a single bolt. To save on equipment cost, sweep augers can be used on multiple similar sized bins.

Hoppers...

All models 30' and up have 3 hoppers, 42' and up have 4 hoppers. The gates are controlled by rack and pinion mechanisms.

Misc...

The system is complete with bin wall plates, the gate crank, sweep safety stop, hopper flanges, decals, and an industrial grade enamel paint finish.

SWEEP OPTIONS...

Power sweeps comes standard with a 16.4:1 gearbox reduction drive wheel. The sweep tractor is optional and recommended for large power-sweep models, see feature frame for more details.

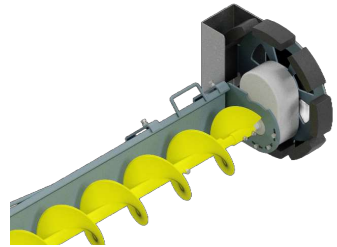

Sweep lengths are adjustable +/- 12" to optimally fit bin diameter, eliminating hours of manual labor.

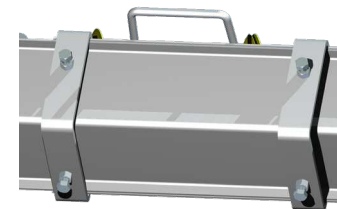

Backboard extensions are secured by 4 bolted connections. Length adjustment takes just minutes.

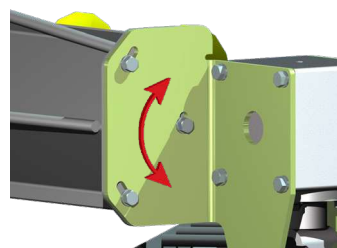

The backboard tilts +/- 10°, to adjust the sweep from touching the floor and giving you the option of getting as close to the floor as possible for a clean sweep, in addition to adding more working hours to the sweep drive wheel as it wears.